

MARYLAI

CITY OF SEBASTOPOL - SCULPTURE

LETTER OF INTEREST:

As a multifaceted artist based in Los Angeles, California my work ranges from paintings, large scale murals to sculptures. I am interested in this sculpture for this public space in the City of Sebastopol because this sculpture brings an uplifting energy. The AR activated sculpture is a wonderful experience for the community to engage with. This Dream Portal Sculpture is already fabricated and currently at the W Hotel entrance in Los Angeles, CA. My artist residency ends May 2024 so it would be the perfect time for the Dream Portal to find a new home and inspire others with the message to create our own doors and follow our dreams.

ARTWORK DESCRIPTION/ DEPICTION:

Mary Lai believes Pablo Picasso's words, "Everything you can imagine is real." The Dream Portal is more than just having the dream, it is about creating it into reality. When opportunities are not available to someone because of gender, race and/or background, this should not stop us. This should ignite us to create our own doors and build our own path of opportunity. This vibrant sculpture is interactive with an AR activation to be experienced in person. The arched doorway looks like a rainbow with sun and cloud is loved by all ages with a positive message and thoughtfully designed. This sculpture is 48.5" w x 68" h x 17" d and durable for the outdoors due to the extra wood material with automotive paint finish. It would be a wonderful opportunity to have the Dream Portal sculpture in the City of Sebastopol for the public to enjoy.



South Entry of the Joe Rodota Trail (Sebastopol, CA)

MARYLAI

CITY OF SEBASTOPOL - SCULPTURE

TIMELINE:

Installation: Sculpture is ready and can be delivered early May 2024 in schedule with the City of Sebastopol.

BUDGET:

\$15,000: A. Artist Fees/ Design Fees B. Materials, Equipment, and Production costs C. Studio Fees

\$3500: D. Transportation of finished artwork to site in Sebastopol

\$2500: E. Installation costs, including any equipment rental

\$500: F. Lighting costs

\$500: G. Insurance

\$3000: H. Taxes I. Documentation

TOTAL: \$25,000

IMAGES OF PAST WORK:



Mary Lai, Dream Portal, Extruded wood with automotive paint, 48.5" w x 68" h x 17" d, 2023, W Hotel (consignment for Artist Residency duration)

MARYLAI

CITY OF SEBASTOPOL - SCULPTURE

MORE IMAGES OF PAST WORK:

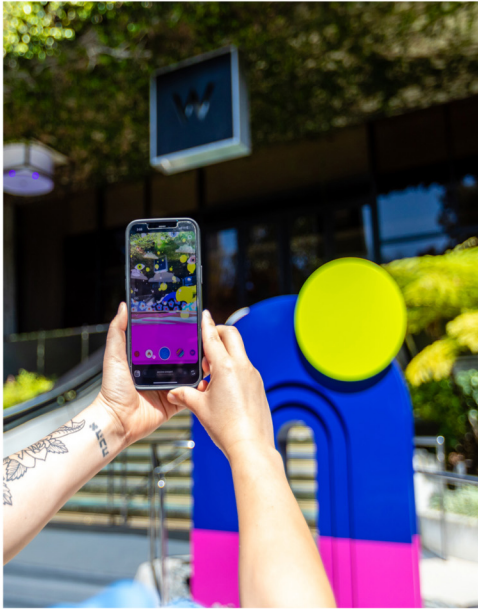

DREAM PORTAL SCULPTURE



- USE PHONE CAMERA APP TO SCAN QR CODE
- INSTAGRAM OPENS AUTOMATICALLY FOR AR INTERACTION
- HOLD DOWN CIRCLE BUTTON TO RECORD

TAG TO SHARE
ARTWORK: @MARYLAI.CO | AR: @FUTUREARTSCO
COLLAB: @WLOSANGELES | MUSIC: @LINNEY

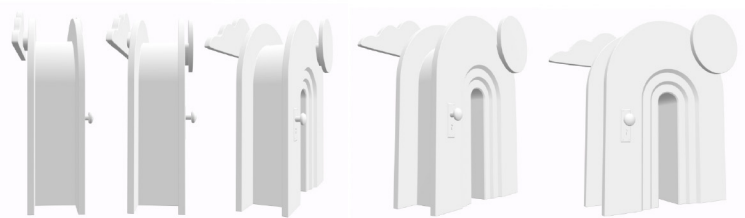

Mary Lai, Dream Portal V3, Extira wood with automotive paint, 68" w x 94.5" h x 20" d, 2023, Context Art Miami Art Fair

MARYLAI

CITY OF SEBASTOPOL - SCULPTURE

MORE IMAGES OF PAST WORK:

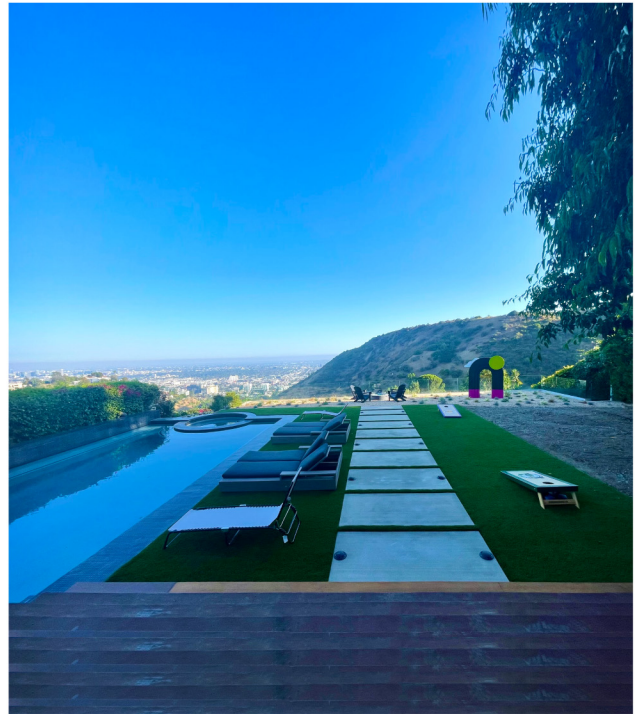

Mary Lai, Dream Portal V2, Extira wood with automotive paint, 68" w x 94.5" h x 20" d, 2023, Commissioned art collector for private home in Hollywood Hills - \$60K

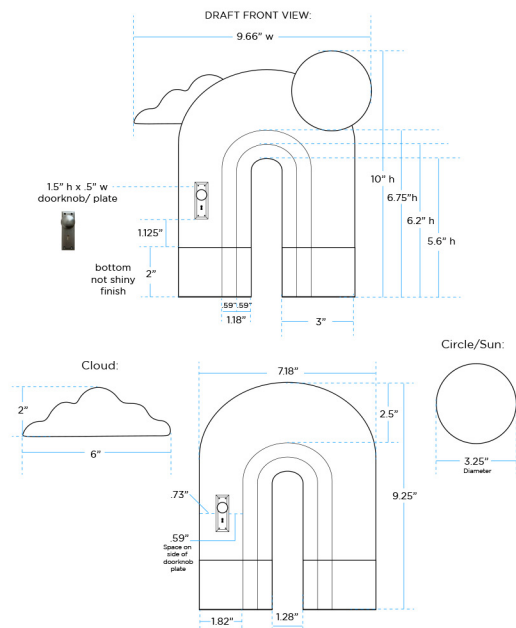

Mary Lai, Dream Portal(bles), Stainless steel with gold finish, 15" w x 16" h x 4" d, 2023, Context Art Miami Art Fair



MARY LAI

CONTACT

phone:

email:

Los Angeles, CA 90031

PROFILE

Versatile designer & artist
Resourceful entrepreneur
Creative thinker & leader

PORTFOLIO

www.marylai.com

SOCIAL



@marylai.co



@marylai_co

WORK EXPERIENCE

VISUAL ARTIST & DESIGNER

September 2017 - Present | Los Angeles, CA

ART: Created vibrant contemporary artwork that was exhibited at leading art fairs, galleries and hotels from Los Angeles, New York, Dallas, Miami to Seoul. Named the Artist in Resident 2023 for W Hotel in West Beverly Hills. Mixed media work ranges from paintings to large scale murals and installations. Presented at solo & group exhibitions, curated several art events, and spoke on NFT panels from SXSW, NFT.NYC to NFT Expoverse. Featured on HBOMax Craftopia Season 2 Episode 4 (Winner). Created Hungry Artist project with the mission to empower more artists.

DESIGN: Brand development from story/copy, logo design, style guide to establishing brand DNA via typography, color, photography and videography. Innovative product development from ideation, sketch, CAD, product specs to working closely with manufacturers domestic and international. Art directing photo/video shoots to creating compelling content that is on brand. Design and managing websites, e-commerce, marketing, production, sales to social media. Edited client list includes St. Jude x Vayner, Rhea/Mark Wahlberg, Brandon Boyd and Evermore Gear.

ART DIRECTOR @ BAM LUXURY DEVELOPMENT GROUP

March 2015 - August 2017 | Los Angeles, CA

Managed design projects with a high-performing team of creatives to develop custom artwork and interior elements for a luxury turn key home in Bel Air. Worked directly alongside the CEO to create extraordinary art and designs for the property from sketch, sourcing, CAD to full fabrication. Established the in-house art division that created bespoke artwork, prints, sculptures and installations for the property as well as exhibited at global art shows and galleries. Art directed photo shoots and led design team to create beautiful visual solutions for marketing the art and home cohesively in collaboration with the realtors and PR team.

DESIGNER & FOUNDER @ MARYLAI HANDBAGS

February 2012 - December 2016 | New York, NY - Los Angeles, CA

Created an award-winning leather handbag brand. Developed entrepreneurial skills running a small business and capable of multi-tasking several roles from branding, product design, sourcing, marketing, web, social media, production, sales to logistics. Train with top sample makers at an atelier in the Garment District to create patterns and handcraft handbags from sketch to completion. Worked closely with leather tanneries, hardware manufacturers, sample makers and factories. Hand selected for a trunk show at Henry Bendel, to speak at a design panel with DVF, and a trip to Florence, Italy to visit bag makers. Showcased at trade shows from Capsule Paris, Capsule NY, EDIT Show and MAGIC Vegas.

EDUCATION

MASON GROSS SCHOOL OF THE ARTS

Rutgers University
New Brunswick, NJ

BFA in Graphic Design -
1999 - 2003

AWARDS

HBOMax CRAFTOPIA
Winner

Open Rising Star of
Fashion Award 2013

Independent Handbag
Designer Award 2013

Guess Brand Handbag
Design Award 2015

LANGUAGES

English

Korean

ARTIST STATEMENT

Art is a universal language that can speak to anyone. My dreamer mindset is reflected in the vibrant mixed media artwork that aims to uplift and evoke emotion. As a contemporary mixed media artist, I combine abstract geometric forms with vibrant illustrations playing in the intersection of art and design.

With over 20 years in the creative industry, I use my experiences to create a range of artworks, murals and sculptures where art is experienced.

SENIOR HANDBAGS & ACCESSORIES DESIGNER @ GLOBAL BRANDS GROUP (LF USA)

July 2007 - February 2012 | New York, NY

Identified seasonal trend direction with a critical eye - travel to Paris, London and Tokyo for trend shopping and trend report. Created concepts, sketches, prototypes, patterns/prints and design specs. Product development trips to South Korea every quarter to complete each collection in a fast paced environment with strict deadlines. Source leathers and materials with a high level of taste within target pricing and production in mind. Give direction and feedback to design team to achieve desired outcomes with a strong aesthetic sense for each brand ethos. Art directed a custom showroom design every market.

CV EXHIBITONS // SHOWS:

CONTEXT & AQUA Art Miami // Miami, FL - December 2023

MOMENTUM ART SHOW - Keystone Gallery // Los Angeles, CA - Summer 2023

W HOTEL (Artist in Resident 2023) // West Beverly Hills, CA - May 2023

LA ART SHOW // DTLA - February 2023

SCOPE MIAMI - ART BASEL // Miami, FL - December 2022

ST. JUDE X VAYNER EXHIBITION // Miami, FL - December 2022

ARTSHARE LA // DTLA, CA - December 2022

THE OTHER ART FAIR // Santa Monica, CA - September 2022

Digital Art Exhibition - Deviant Art // Hollywood, CA - August 2022

PLAS Korea @ COEX - Gallery PADO // Seoul, Korea May 2022

ART MARKET SF // San Francisco, CA - April 2022

THE OTHER ART FAIR // Los Angeles, CA - April 2022

RED DOT MIAMI WYNWOOD - PERSEUS Gallery // Miami, FL - December 2021

THE OTHER ART FAIR // Brooklyn, NY - November 2021

BFAA ART FAIR - Gallery PADO // Busan, Korea October 2021

THE OTHER ART FAIR // Santa Monica, CA - September 2021

THE OTHER ART FAIR // DTLA, CA - June 2021

NOSTALGIA SOLO EXHIBITION - START LA Gallery // Los Angeles, CA - Nov 2020

RED DOT MIAMI WYNWOOD - PERSEUS Gallery // Miami, FL - December 2019

SBG HOTELS SOLO SHOW - CHESTERFIELD HOTEL // Miami, FL - December 2019

DESIGNERCON - ANAHEIM CONVENTION CENTER // Anaheim, CA - November 2019

SNAPCHAT SPECTACLES X RON ROBINSON EVENT // W Hollywood, CA - Nov 2019

THE OTHER ART FAIR LA // Santa Monica, CA - October 2019