

Agenda Report Reviewed by:
City Manager: 

CITY OF SEBASTOPOL
CITY COUNCIL
AGENDA ITEM

Meeting Date: May 3, 2022
To: Honorable Mayor and City Councilmembers
From: Toni Bertolero, Engineering Consultant
Subject: One Bay Area Grant Cycle 3 (OBAG 3) for Bodega Avenue Bike Lanes and Rehab Project
Recommendation: Authorize Staff to Pursue OBAG 3 for Bodega Avenue Bike Lanes and Rehab Project
Funding: Currently Budgeted: _____ Yes _____ No N/A

Account Code/Costs authorized in City Approved Budget (if applicable) AK (verified by Administrative Services Department)

INTRODUCTION/PURPOSE:

The item is to request Council authorize staff to pursue the One Bay Area Grant Cycle 3 (OBAG 3) for the Bodega Avenue Bike Lanes and Rehab Project.

BACKGROUND :

The City Council approved the design contract with Wood Rodgers in March 2021 and the project is current in the design and environmental review phase. During the design work, it became apparent that there would not be sufficient funding to complete the entirety of the Bodega Avenue project which runs from High Street to Pleasant Hill Road. The OBAG 2 grant awarded to the City is \$1.1 million and the total cost of the project is currently projected to be \$4.3 million. Because of the funding constraints, the project is being phased, with Phase 1 being High Street to Robinson Road/Nelson Way (specific end location is dependent on bid climate) and Phase 2 continuing on to Pleasant Hill Road. Phase 1 project has sufficient funding and is included in the proposed Fiscal Year 2022-23 Capital Improvement Program (CIP) budget at an estimated construction cost of \$1.44 million.

The Bodega Avenue Bike Lanes and Rehabilitation Phase 2 project is the second phase of a three-phased bicycle connectivity project located on Bodega Avenue through the City of Sebastopol. The State Route 12-Bodega Avenue corridor is the primary regional east-west route connecting the City of Sebastopol with Santa Rosa and eastern Sonoma County to the east and Bodega Bay and the coastal western Sonoma County to the west. Bodega Avenue is designated as an arterial road and serves both local City traffic as well as regional through traffic between Santa Rosa and the coastal western areas. Within the city, Bodega Avenue is primarily a three-lane street or two lanes with parking. At its eastern end near South Main Street, Bodega Avenue carries approximately 11,900 vehicles per day on the project segment. This Phase 2 project proposes to add approximately 0.35 miles of Class II bike lanes on Bodega Avenue between Nelson Way and Pleasant Hill Avenue as well as rehabilitation of the pavement. Phase 1 which is currently programmed and is the eastern segment from High Street to Nelson Way includes bike lanes and pavement rehabilitation.

DISCUSSION:

The Phase 2 project would extend the bike lanes from Nelson Way to Pleasant Hill Road. Pleasant Hill Road provides access to northwestern Sebastopol neighborhoods to the north including Covert Lane which is the primary access to Ragle Ranch Park operated by Sonoma County. Pleasant Hill Road to the south provides access to County areas to the southwest including routes to State Route 1. The third phase, referred to as "West Side Bicycle and Pedestrian

Access Phase 1,” is a separate application and would extend the bike facilities to the western City limits where it would connect to a County Class I bike path and will be part of the Active Transportation Grant Cycle 6 (ATP 6) that staff is currently applying for award.

As an aside, there was an opportunity to apply for a Community Project Funding, the new terminology that is being used for earmarks. The Federal Fiscal Year 2022-23 Appropriations Act was the first time in a decade that earmarks are being after many accountability reforms. An invitation to submit for community project funding was released by Congressman Jarred Huffman’s office on April 6, 2022, and applications were due on April 15, 2022. Only 15 applications will be awarded and given the high competitiveness of this earmark funding, it is not too likely that the City’s application will be awarded, but staff decided to try anyway and filled out an application to fund the Phase work by the April 15 deadline.

The Phase 2 project is estimated to cost \$2.9 million and is currently unfunded. Staff is requesting authorization to proceed with applying for the OBAG 3 funding.

GOALS:

This action supports the following City Council Goals and General Plan Action:

- Goal 2 - Maintain, Improve and Invest in the City’s Infrastructure (Water, Sewer, Streets, Circulation, Parks, Storm Drains and Public Facilities).
- Circulation 2 – Maintain and expand a safe and efficient pedestrian, bicycle, and transit network that connects neighborhoods with key destinations to encourage travel by non-automobile modes while also improving public health.

PUBLIC COMMENT:

As of the writing of this staff report, the City has not received any public comment. However, staff anticipates receiving public comment from interested parties following the publication and distribution of this staff report. Such comments will be provided to the City Council as supplemental materials before or at the meeting. In addition, public comments may be offered during the public comment portion of the agenda item.

PUBLIC NOTICE:

This item was noticed in accordance with the Ralph M. Brown Act and was available for public viewing and review at least 72 hours prior to schedule meeting date.

FISCAL IMPACT:

There is no fiscal impact with this action.

RECOMMENDATION:

Staff recommends the Sebastopol City Council authorize staff to pursue the OBAG 3 for the Bodega Avenue Bike Lanes and Rehabilitation Project (Phase 2).

Attachment:

Project Map

LEGEND

- Replace Curb Ramp
- Replace Curb Ramp and Replace/Relocate Pedestrian Push Button
- Cold Plane and Overlay Pavement

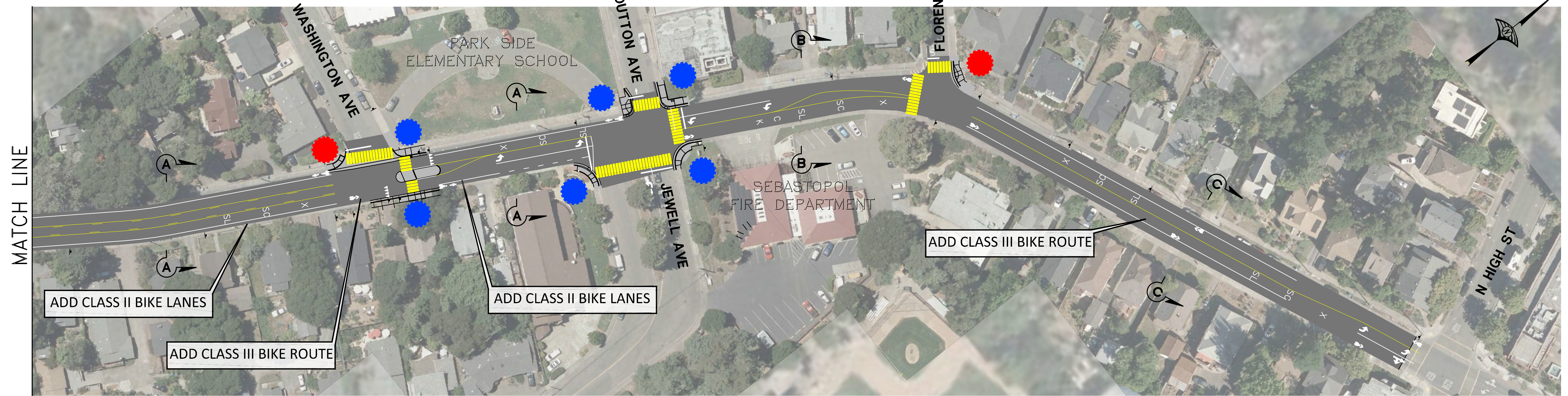
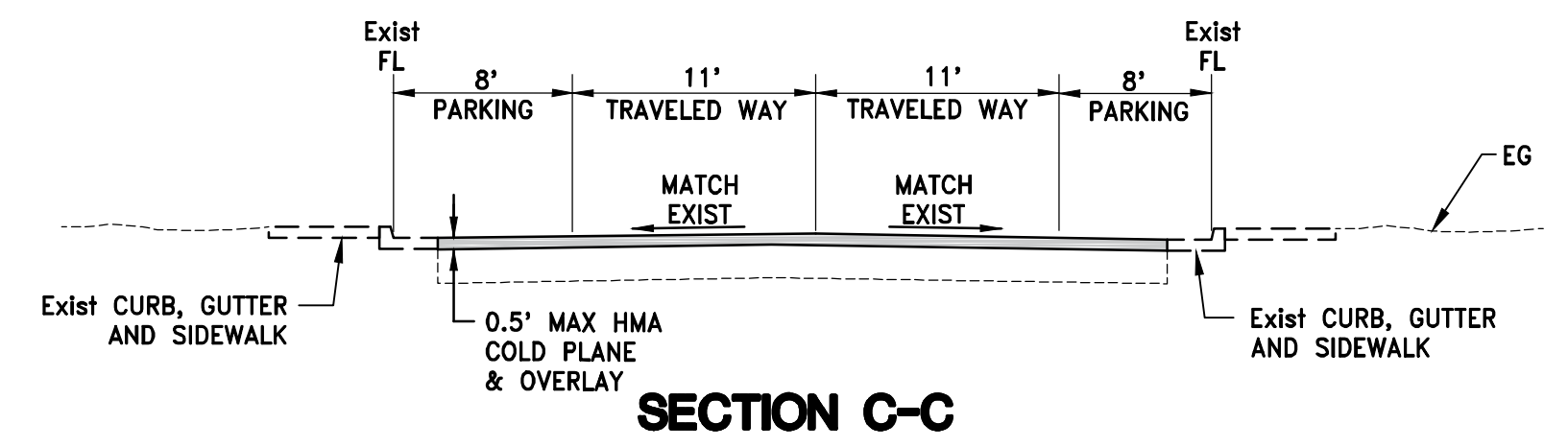
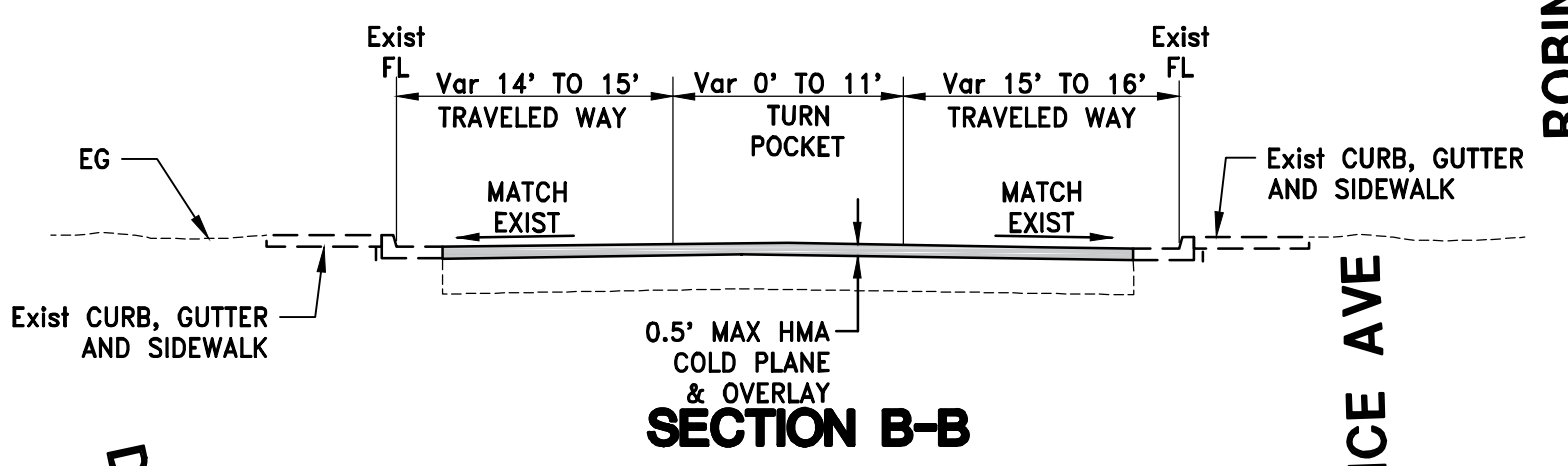
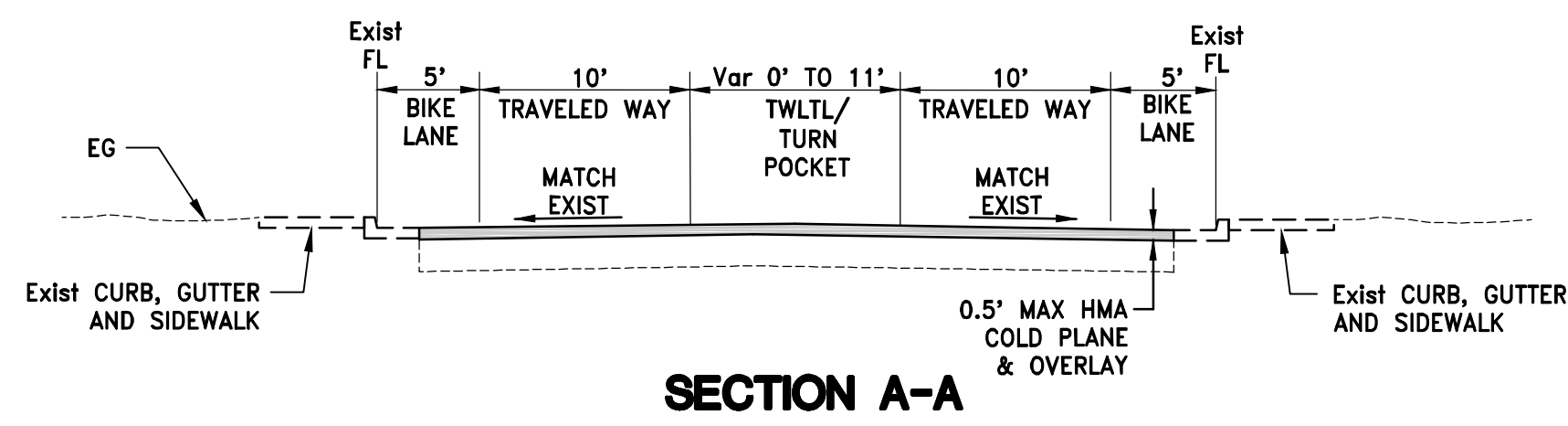

BODEGA AVENUE RECONSTRUCTION PHASE 1



LEGEND

- Replace Curb Ramp
- Replace Curb Ramp and Replace/Relocate Pedestrian Push Button
- Cold Plane and Overlay Pavement or Rehabilitation

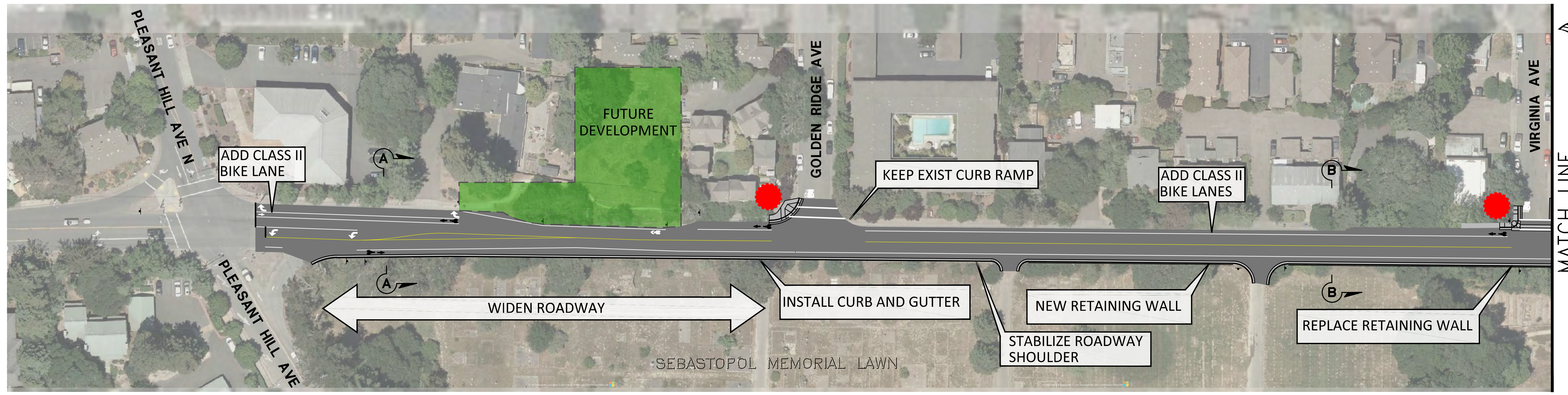

MATCH LINE

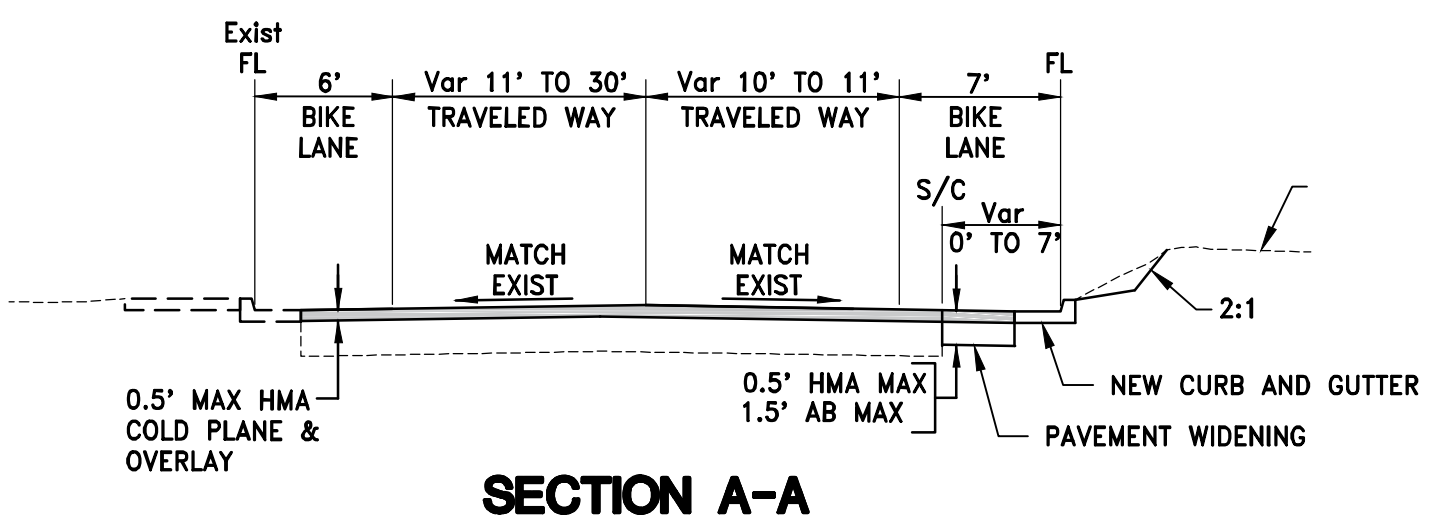

SECTION A-A

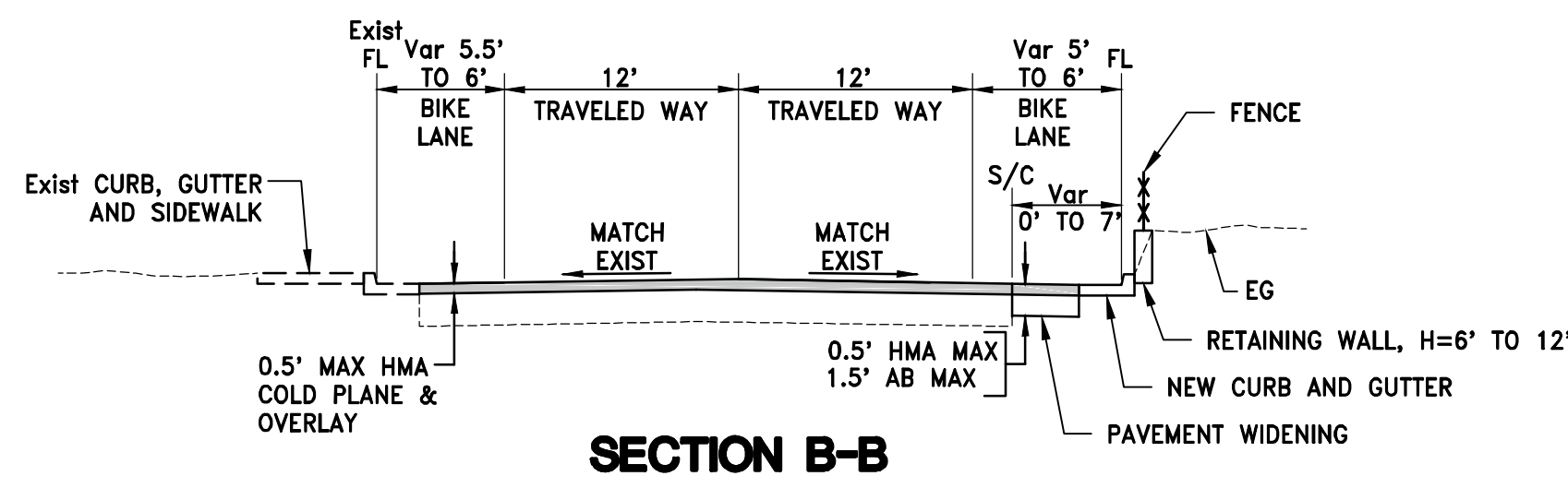

SECTION B-B

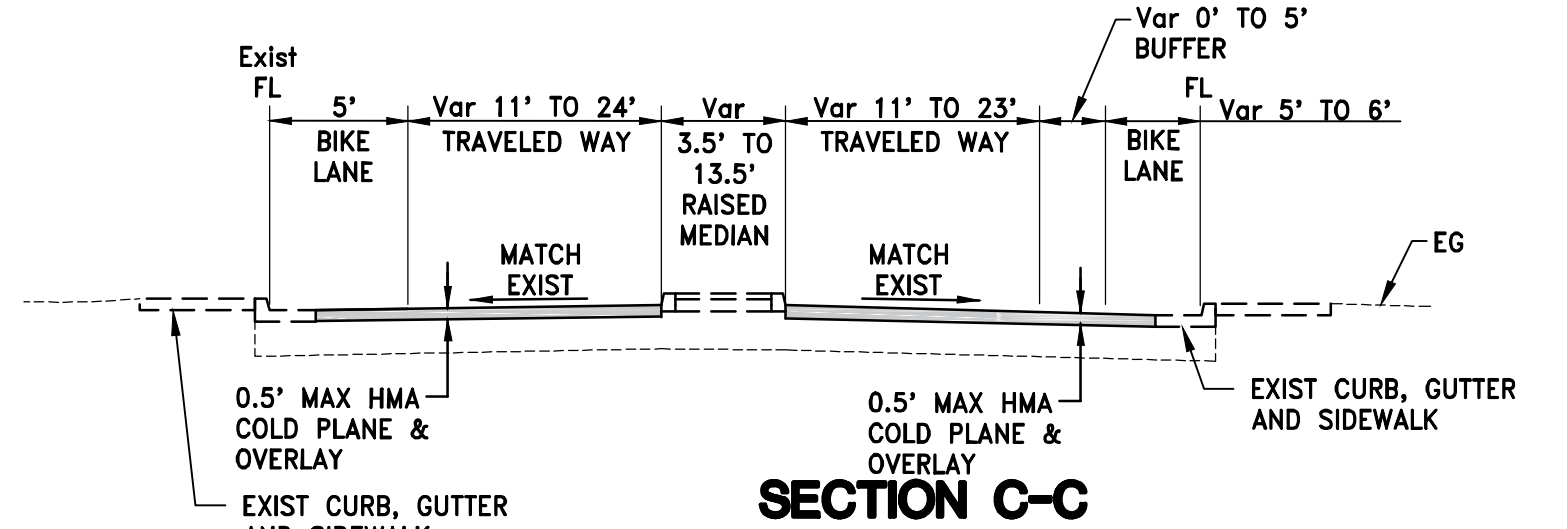

SECTION C-C

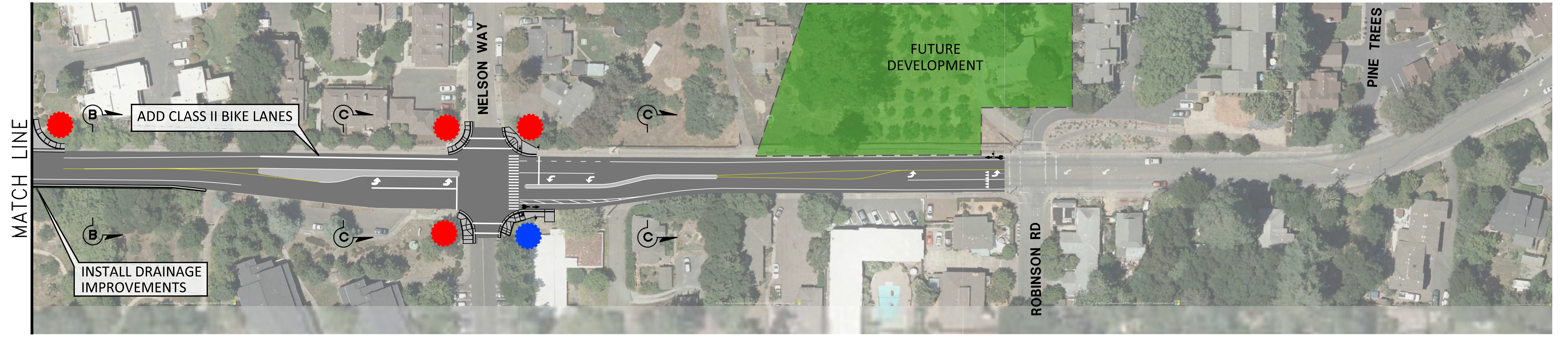

MATCH LINE

BODEGA AVENUE RECONSTRUCTION PHASE 2

