

Agenda Report Reviewed by:
City Manager: 

CITY OF SEBASTOPOL
CITY COUNCIL
AGENDA ITEM

Meeting Date: August 1, 2023
To: Honorable Mayor and City Councilmembers
From: Jack Piccinini – Interim Fire Chief
Subject: Consideration of Purchase of Pierce Enforcer Type 1 Fire Engine – Total Purchase Price \$938,744.82 and authorize the City Manager to Enter into the Lease Agreement with Community Leasing Partners
Recommendation: That the City Council Approve the Purchase of a New Type 1 Fire Engine to Replace the Existing 1990 Type 1 Fire Engine and authorize the City Manager to enter into the Lease Agreement with Community Leasing Partners
Funding: Currently Budgeted: Yes No Not Applicable

Account Code: 104-31-02-5100

Costs authorized in City Approved Budget: Yes (Finance Initialed AK) No (Finance Exempt)

INTRODUCTION/PURPOSE:

The item is to request Council approve \$938,744.82 for the purchase of a new Pierce Enforcer Type 1 Fire Engine to Replace Existing the 1990 Type-1 Fire Engine and authorize the City Manager to enter into a lease agreement with Community Leasing Partners financing company.

BACKGROUND:

As a part of the 23/24 budget process the council approved \$300,000 to serve as a down payment for the purchase of a new type 1 engine to address the critical need of replacing a 33-year-old fire engine. The council approved these funds based on being able to move forward on the engine purchase on a lease purchase option strategy. Staff have worked with the fire engine manufacturer who has provided a proposal for an engine that meets the needs of the city.

DISCUSSION:

The SFD operates with a fleet of two Type 1 fire engines, one 100' aerial ladder truck, one Type 3 fire engine, and a rescue squad. Maintaining two Type 1 engines is critical in providing the necessary pumping capacity for fighting building fires and for meeting the ISO fire flow requirements to achieve Sebastopol's ISO rating of 3. Additionally, it is critical to have two Type 1 engines so that when one engine is unavailable due to a commitment on an incident, or out of service due to maintenance or mechanical issues, the second engine is available. Having like operability of the engines is also critical as pumping operations, equipment placement, technology and functionality is the same between engines.

Fire apparatus replacement standards are based on NFPA 1901, best practices and standards established by the League of California Cities. These standards require that engines be replaced every 25 years. As the Matrix

consultant report indicated, the current front-line engine is 12 years old and the second line engine is 33 years old, eight years past its recommended replacement age.

Agenda Item: Added July 27 2023

The proposal before the council is to purchase a Pierce Enforcer Type 1 Engine. The proposed engine, with little exception, is identical to the current front-line engine. By following this strategy, the following benefits are achieved:

- Volunteers operate on pieces of equipment with the same pump and pump operations.
- The layout of compartments will be the same between engines and therefore being able to maintain a standard inventory of equipment and its location on the fire engine is achieved.
- By duplicating our existing fire engine, which was built by Pierce, specifications have already been developed. This significantly shortens the process as there is no need to start from ground zero in developing new specifications.
- Using the current engine specs as the working model places the engine in Pierces' BMP program which will shorten build time.
- Standard and operational consistencies is also extended when working with neighboring departments which also currently have Pierce fire engines. (Graton FD - 1 Pierce in service 1 on order; Santa Rosa 7 as examples).
- Pierce exclusively provides the Paccar MX13 motor, which is a high performing, highly reliable motor that comes with significant savings over other diesel motor manufacturers.
- The Enforcer Cab and chassis are proprietary to Pierce and provide for operational consistency between engines and is proprietary to Pierce.
- Foam tank and light tower are proprietary to Pierce and provide for operational consistency between engines.

The City of Sebastopol, being members of the Sourcewell Consortium Sourcewell is a governmental agency that has the legal authority for national solicitations. This vets competitive pricing for governmental purchases. Members can use Sourcewell awarded contracts which have gone through the competitive bid process and legally satisfies bid requirements. Pierce as allowed a \$17,185.07 discount for use of the Sourcewell Consortium

As indicated, one of the important strategies to this purchase to based on a lease purchase plan. This strategy was presented to the budget ad hoc committee as the best method to expedite the replacement of the 1990 fire engine, placing the apparatus replacement plan on track and preventing delays in the purchasing process. Any delays in attempting to achieve saving will highly likely be offset by the rampant cost increases that are occurring in this industry. Attached are leasing proposals from Community leasing Partners. Interest rates are consistent with other lenders. By executing this option, Pierce has allowed a pre-payment discount of \$113,300.67 for 100% payment at time of order. Proposals from Community Leasing Partners are attached. It is recommended that executing a \$300,000 down payment and payment of \$238,050.49 per year for 3 years is most prudent.

ENVIRONMENTAL REVIEW:

The proposed action is exempt Yes No from the requirements of the California Environmental Quality Act (CEQA)

GOALS:

This action supports the following City Council Goals and General Plan Actions:

- CSF 1: Provide High Quality Community Services, facility and Infrastructure to All Residents, Business and Visitor in Sebastopol.

PUBLIC COMMENT:

As of the writing of this staff report, the city has not received any public comment. However, staff anticipates receiving public comments from interested parties following the publication and distribution of this staff report. Such comments will be provided to the City Council as supplemental materials before or at the meeting. In addition, public comments may be offered during the public comment portion of the agenda item.

Agenda Item: Added July 27, 2023
City Council Meeting Packet of: August 1, 2023
Page 2 of 7

PUBLIC NOTICE:

This item was noticed in accordance with the Ralph M. Brown Act and was available for public viewing and review at least 72 hours prior to the scheduled meeting date.

FISCAL IMPACT:

As mentioned above, it is proposed and recommended that the City Council authorizes the City Manager to enter into a lease agreement with Community Leasing Partners financing company. Staff is proposed to select Option 1 with a 3 years terms at the interest rate of 5.79% with a \$300,000 down payment and each payment of \$238,050.49 per year for the next 3 years. The total cost of this Type 1 Engine at the end of the lease term at approximately \$1,014,151

The deposit amount of \$300,000 is allocated in FY23-24 adopted budget. By entering into the 3 years lease agreement, the City is committing of approximately \$238,000 annually for fiscal year 24-25, 25-26, 26-27.

RECOMMENDATION:

Staff recommends the Sebastopol City Council Approve the purchase of the Pierce Enforcer Type-1 Fire Engine and execute the purchase agreement based on Golden State Fire Apparatus proposal 50726-23; and that further, staff be authorized to execute a lease purchase agreement with Community Leasing Partners in conjunction with the execution of the purchase agreement for the engine.

Attachments:

Bid pricing cost breakdown.

Drawing of the proposed engine.

Proposed lease options from Community Leasing Partners.



PRODUCT PROPOSAL FOR:

City of Sebastopol Fire Department
7425 Bodega Ave
Sebastopol, CA 95472

Sales Consultant

Jon Bauer
jbauer@goldenstatefire.com
 Mobile: 530.351.2151

SUBMITTED DATE	EXPIRATION DATE	GSFA PROPOSAL #	MANUFACTURER BID #	MANUFACTURER	CONSORTIUM
7/26/2023	8/25/2023	50726-23	1022	Pierce Mfg.	Sourcewell (City of Sebastopol Member ID# 117686)

Golden State Fire Apparatus, Inc. ("GSFA") is pleased to provide this proposal for the fire apparatus(es) and equipment identified below (the "Product") to **City of Sebastopol** ("Customer") for consideration. This proposal (this "Product Proposal") includes the following exhibits attached hereto: the Standard Terms and Conditions attached as Exhibit A (the "Terms and Conditions"); the Product Specifications attached as Exhibit B (the "Specifications"); the Product Warranties attached as Exhibit C; and the Dealer Supplied Products and/or Services attached as Exhibit D (the "Dealer Supplied Products/Services List") (all of the foregoing, collectively, the "Agreement"). Through its signature below or other Acceptance (as defined on page 2), Customer acknowledges having received and read, and agrees to be bound by, the Agreement. The Agreement shall be effective as of the latest date appearing in the signature blocks below (the "Executed Date").

ITEM	PRODUCT DESCRIPTION	UNIT PRICE
A	One (1) Pierce Enforcer Type 1 Engine	\$987,720.82
B	<i>Pre-Payment Discount for 100% Payment at Time of Order (the "Prepayment Discount")</i>	<i>(\$113,300.67)</i>
C	<i>Discount for Sourcewell consortium purchase (Product ID #259)</i>	<i>(\$17,185.07)</i>
D	SUBTOTAL	\$857,235.08
E	9.25% State Sales Tax	\$79,294.24
F	California Tire Fee	\$10.50
G	100% Performance Bond	\$2,204.99
H	GRAND TOTAL PURCHASE PRICE	\$938,744.82

PAYMENT TERMS – Customer shall pay the total purchase price set forth directly above (the "Grand Total Purchase Price") to GSFA within fifteen (15) calendar days of the Executed Date. If payment of the Grand Total Purchase Price is late, a late fee as specified in section 6 of the Terms and Conditions may be applied, and the Prepayment Discount may be adjusted, and the Grand Total Purchase Price increased in accordance with section 2.c of the Terms and Conditions. Customer shall pay any balance due as a result of Change Orders to GSFA at the time of GSFA's delivery of the applicable Product to Customer's address listed above (or Customer's pick up of such Product at GSFA's facilities, as applicable and if approved by GSFA).



1 PRODUCT PROPOSAL

PUMPER
 BODY
 Medium Aluminum 2nd Gen Pumper
CHASSIS
 Pierce Chassis

CHASSIS
 AXLE FRONT CUSTOM
 15,500 lb 11k-4 Axle
 AXLE REAR
 24,000 lb 11k-4 Axle
ENGINE
 510 HP Power Take Off Engine
TRANSMISSION
 Allison 300 Gen, 3000 DPS P
BUMPER
 1st Extended Stainless Steel
CAB
 7000 Entrance Cab

BODY
WATER TANK
 500 Gallon High Water Tank
COMP, PUMPER, REAR
 37.75" HP Roll-Up Rear Comp.
COMP, PUMPER, LEFT SIDE
 145" Roll-Up Full Height Front & Rear
 1.50" Standard Capacity
 5' Longue Side Roll Side
COMP, PUMPER, RIGHT SIDE
 145" Roll-Up Full Height Front & Rear
 1.50" Standard Capacity
 5' Longue Side Roll Side

FIRE SUPPRESSION
PUMPHOUSE
 45" Control Zone Side Mount
PUMP
 2000 GPM Maximum Flow
GROSS LAYS, 1.50"
 1.50" Standard Capacity
GROSS LAYS, 2.50"
 2.50" Standard Capacity
SPEED LAYS
 Speed Lays Not Required
GENERATOR
 Generator Not Required
FOAM SYSTEM
 Having a Single Agent Foam System
FOAM Cell
 20 Gallon Foam Cell, Not Reduced Water

Side Roll and Frontal Impact Protection

NOTE
 DIMENSIONS SHOWN ARE APPROXIMATE
 AND ARE SUBJECT TO MINOR DEVIATIONS
 AS MAY OCCUR ON BE NECESSARY IN
 CONSTRUCTION.
 FINISH DETAILS NOT SHOWN.

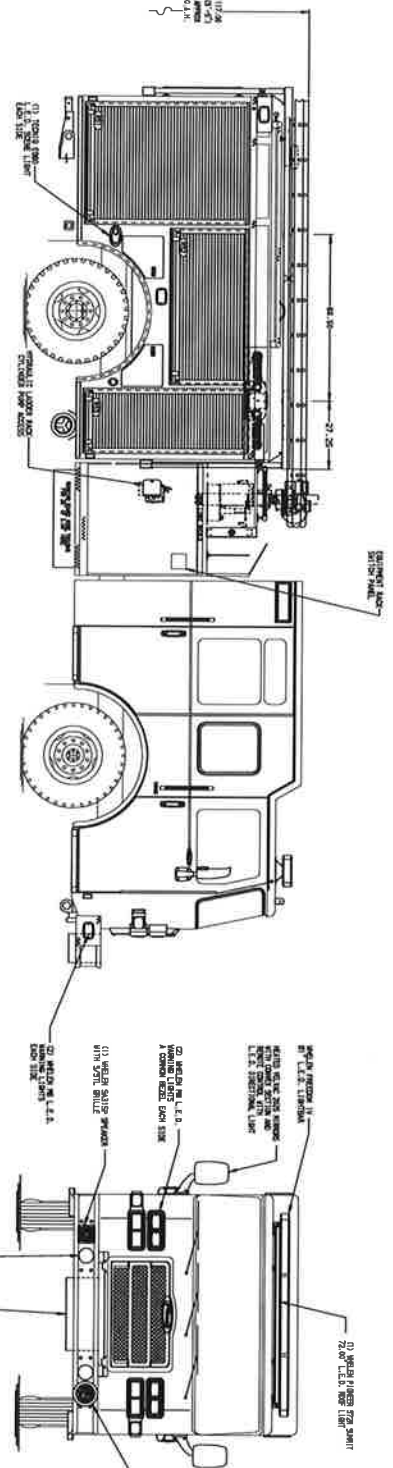

BOSSBRED CAPACITY

110 1	110 1
200" or 2.50' S.L. HOV 10	200" or 2.50' S.L. HOV 10
300" or 3.50' S.L. HOV 15	300" or 3.50' S.L. HOV 15
400" or 4.50' S.L. HOV 20	400" or 4.50' S.L. HOV 20
500" or 5.50' S.L. HOV 25	500" or 5.50' S.L. HOV 25

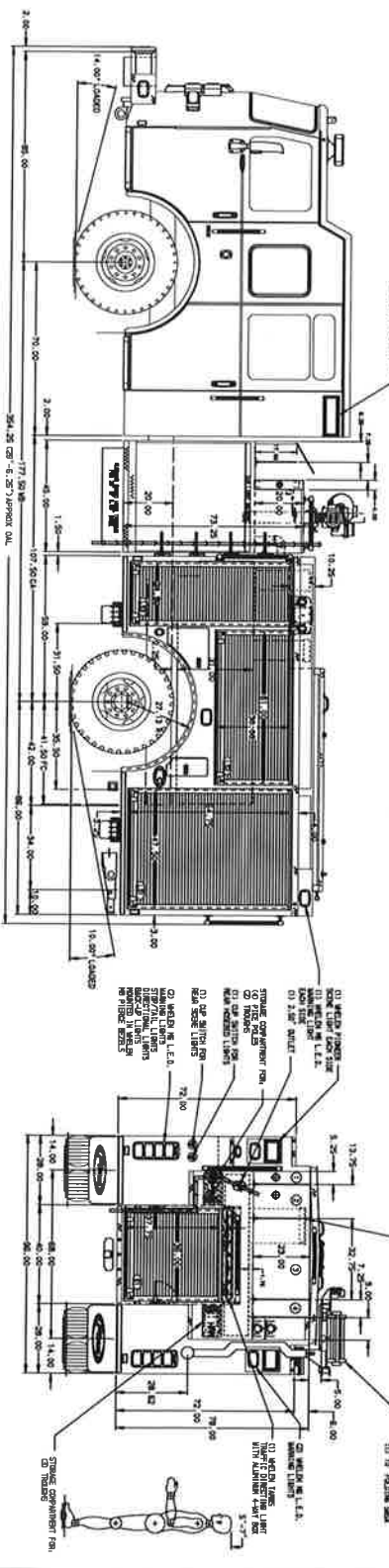

MAXIMUM O.A.H. 120.00"

CUSTOMER APPROVAL

APPROVED BY:	DATE:
CHASSIS DATA:	DATE:
TITLE:	DATE:
PIERCER:	DATE:
ENFORCER:	DATE:

Pierce MANUFACTURING INC.

JOB NO. PRELIM	DATE
SCALE 1:24	DATE 18JUL23
DRAWN BY MHP	DATE
CHECKED BY	DATE
SHEET NO. 1 OF 1	DATE

70945



COMMUNITY LEASING PARTNERS

Phone: 888.777.7850
 Fax: 888.777.7875
 Cell: 785.313.3154
 215 S. Seth Child Road
 Manhattan, KS 66502
 www.clpusa.net

July 26, 2023

Customer Name: Sebastopol, CA

Equipment: One Pierce Enforcer Type I Engine
 Sales Representative: Jon Bauer @ Golden State Fire Apparatus
 Delivery: TBD

Community Leasing Partners, a Division of *Community First National Bank*, is pleased to present the following financing options for your review and consideration.

Option 1

Total Cost:	\$ 938,744.82	Payment Frequency:	Annual
Down Payment:	\$ 300,000.00	First Payment:	One year from closing
Prepayment Discount:	\$ -		
Amount Financed:	\$ 638,744.82		

Term in Years:	<u>3</u>	<u>4</u>	<u>5</u>
Payment:	\$238,050.49	\$183,046.40	\$150,375.61
Factor:	0.372685	0.286572	0.235424
Interest Rate:	5.79%	5.69%	5.69%

Option 2

Total Cost:	\$ 938,744.82	Payment Frequency:	Annual
Down Payment:	\$ 300,000.00	First Payment:	Two years from closing
Prepayment Discount:	\$ -		
Amount Financed:	\$ 638,744.82		

Term in Years:	<u>3</u>	<u>4</u>	<u>5</u>
Payment:	\$251,843.14	\$193,469.06	\$158,938.00
Factor:	0.394278	0.302889	0.248829
Interest Rate:	5.79%	5.69%	5.69%

- **THERE ARE NO DOCUMENTATION OR CLOSING FEES ASSOCIATED WITH THIS PROPOSAL.**
- Fixed interest rate for the terms provided unless otherwise stated.
- The quoted interest rate is valid for 10-days from the date of the proposal. To lock in the interest rate, a credit submission would be required, and a credit approval attained within the same 10-day period. This financing is to be executed and funded within 30 days of the date of the proposal, or Lessor reserves the right to adjust the interest rate. The proposal is subject to credit review and approval of mutually acceptable documentation.
- This proposal has been prepared assuming the lessee is bank qualified and that the proposed lease qualifies for Federal Income Tax Exempt Status for the Lessor under Section 103 of the IRS Code.

Thank you for allowing Community Leasing Partners the opportunity to provide this proposal. If you have any questions regarding the options presented, need additional options, or would like to proceed with a financing, please contact me at 1-888-777-7850.

Respectively,

Blake J. Kaus
 Vice President & Director of Leasing
blakekaus@clpusa.net